

WARRANTY

The Fire Soaps Automatic Detergent Timer has a one year limited warranty against defective material and workmanship under normal use from the date of purchase. This limited warranty does not apply to any automatic timer which has a life shorter than one year as a result of damage caused by chemicals, corrosion, improper voltage supply, physical abuse or misapplication. Rubber and synthetic rubber parts such as “O” rings, diaphragms, squeeze tubing and gaskets are considered expendable and are not covered under warranty. This warranty is extended only to the original buyer of our automatic timer. If the automatic timer is altered or repaired without the prior approval of Fire Soaps, this warranty will be void.

Defective units or parts should be returned to the factory with transportation prepaid. If inspection shows them to be defective, they will be repaired or replaced without charge, F.O.B. factory. Defensive Solutions Corp/Firesoaps.com assumes no liability for damages. Return Merchandise Authorization (RMA) number to return units for repair or replacement must be granted in advance of return.

Rev. 1. 3/2010



FIRE SOAPS • 780 EAST 134TH STREET
BRONX, NEW YORK 10454

T: 718-502-9577 • F: 718-728-7408
www.firesoaps.com • info@firesoaps.com

FIRE SOAPS AUTOMATIC TIMER

INSTALLATION INSTRUCTIONS

The Fire Soaps Automatic Detergent timer is a one product, push button operated detergent dispenser for washing machines/extractors. The system requires a 110-volt outlet for power. This system has the option of engaging the lockout by snipping one leg of the “high” resistor on the circuit board. *This is a new feature - Please see the section on LOCKOUT for further information. The unit itself is a 110 volt power supply into a 110 volt circuit board. The 110 volt AC output on the white base in the bottom right hand corner of the circuit board goes through a step down transformer and 24 volts AC are fed to the solenoid on the right hand side of the dispenser.

MOUNTING & INSTALLATION

1. MOUNTING & POWER SUPPLY - Use the screws and anchors provided to mount the unit. Make sure that the unit is within reach of a 110-volt outlet. Plug the unit in but DO NOT turn it on.
2. TUBING - Run 1/4” OD tubing from the water supply in the back of the washing machine to the inlet (rear) fitting of the solenoid on the right hand side of the dispenser. Measure and cut another piece of 1/4” OD supply tubing to go between the output (front) fittings of the solenoid to the top of the dispenser bowl.
3. Tighten all fittings. Be certain not to over tighten the fittings



FIRE SOAPS • 780 EAST 134TH STREET
BRONX, NEW YORK 10454

T: 718-502-9577 • F: 718-728-7408
www.firesoaps.com • info@firesoaps.com

PRO 2034 MANUAL LAUNDRY CIRCUIT BOARD & REMOTE BOX LAYOUT

SEE THE CONTROL BOARD LAYOUT FOR ADDITIONAL INFORMATION

The circuit board in the automatic timer has a power switch, a power indicator light and a fuse. There are also two potentiometers for run time control. They are in the center of the board, near the top, and marked FINE (0-25 seconds) and COARSE (0-180 seconds). The top potentiometer, FINE, controls a run time of 0-25 seconds (2.5 seconds of run time per increment). The bottom potentiometer, COARSE, controls a run time of 0-180 seconds (18 seconds of run time per increment). For longer run times, use the bottom potentiometer and fine-tune the run time with the 0-25 second control.

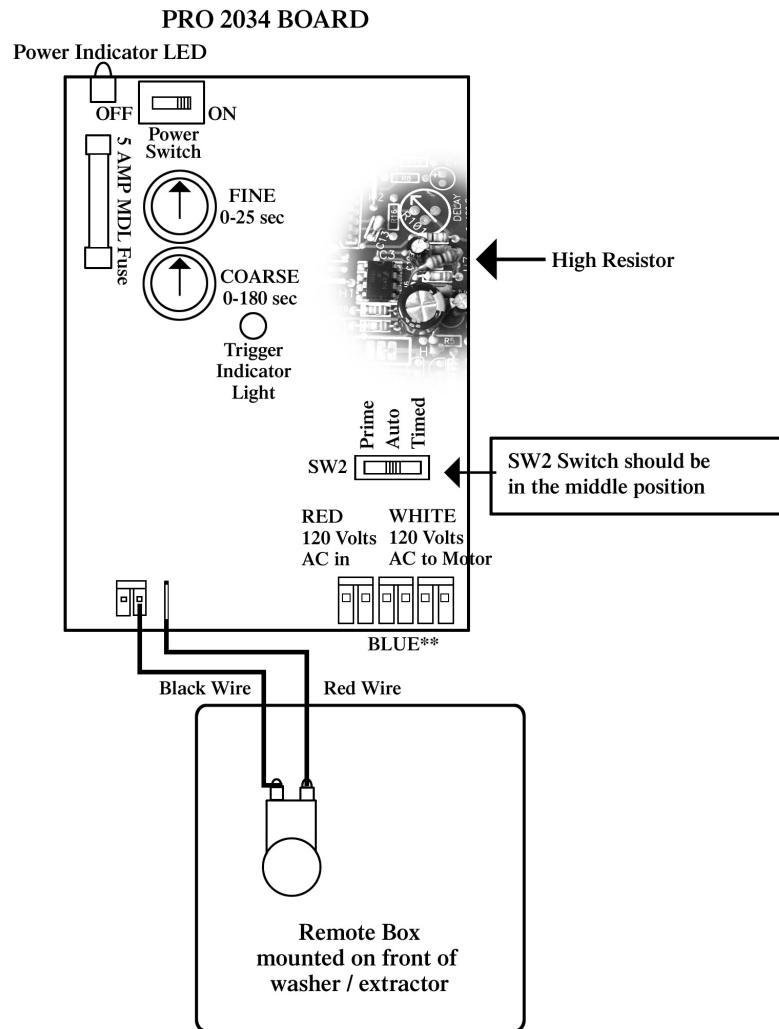

LOCKOUT - WHAT DOES IT MEAN? - HOW TO ENGAGE?

MAKE SURE THAT THE POWER SWITCH IS OFF BEFORE ENGAGING LOCKOUT

All units arrive now without the lockout engaged. This is intended to speed up the Installation for those who will be using the lockout. The lockout should be engaged ONLY AFTER the unit is installed, all tubing is installed, AND the run times have been set and verified.

WHAT DOES THE LOCKOUT DO? The Lockout is intended to prevent the over use of detergents or the “If a little detergent cleans, then a lot of detergent must REALLY clean” theory. Once the lockout is engaged the following will occur: Once the user presses the remote button and starts a cycle, the solenoid will open and run for the length of time that was set during installation. A lockout begins for approximately three minutes during which the user cannot start another cycle. If the button is pressed again after a period of time LESS than the three minute lockout period, the clock is reset and the user must wait another three minutes before the detergent can be dispensed from the pump.

TO ENGAGE THE LOCKOUT – Turn the unit’s power switch to the OFF position. Unplug the unit from the wall. Refer to the board drawing for this resistor location. Cut one of the side leads of the high resistor to engage the lockout. Leave enough of the neutral wire, the leg, on either side so that you can use an alligator jumper in the event that you need to trouble shoot the unit at some point in the future.

KEEP IN MIND - Once the lockout has been engaged, it affects the verify run time position. That is, if the installer wants to change the run time of the pump with lockout and verify time or quantity, the installer will have to wait the full three minutes after triggering the pump with the switch or remote before being able to dispense again.

BEFORE LEAVING THE INSTALLATION

1. Make sure that the three position switches are in the center position (See Illustration) and that the green power indicator light on the front of the lid is lit to indicate that the power is on.
2. If you have engaged the lockout on the unit, make the end user(s) is (are) aware so as to avoid unwanted trouble calls